

KJX Series Plunger Metering Pump

User Manual

Warranty Terms

This manual provides detailed instructions for the proper installation, operation, maintenance, and troubleshooting of KJX series plunger metering pumps. To ensure accurate and efficient use of the product and to prevent personal injury or property damage caused by improper operation, please read this manual carefully before installation or operation. If you have any questions, contact the manufacturer promptly.

The manufacturer provides one-year warranty for defects in its plunger metering pumps arising from manufacturing processes and selected materials under normal operating conditions

The warranty period begins from the date of delivery. Components explicitly identified by the manufacturer as wear parts (such as plunger, packing seals, inlet/outlet valves, oil seals, motor, etc.) are not covered under the warranty. The manufacturer will specify the recommended replacement intervals for these wear-prone components based on the specific application process and operating conditions.

Based on the manufacturer's prior experience, available professional expertise, and process information provided by the user, the manufacturer will recommend materials for liquid-contact components to the user, who shall determine the material selection. The manufacturer assumes no liability for repairs of components or products damaged due to wear or corrosion.

The manufacturer's product warranty coverage does not include defects resulting from improper, misuse, or incorrect operation of the equipment in violation of the operating manual requirements, nor does it cover damage caused by unauthorized repairs. In addition to providing warranty coverage for the products themselves, the manufacturer assumes no liability for any direct or indirect losses or expenses arising from equipment operation, usage connections, or product suitability.

During the warranty period, the manufacturer provides free repair or replacement for products or components that have been inspected and confirmed to fall within the warranty scope. Repair or replacement may be performed either through on-line support service or by returning the equipment to the manufacturer, depending on the specific circumstances. Any repairing must approved by the manufacturer or our representatives.

Catalogue

Safety Precautions for Metering Pump Operations	1
I. Introduction	2
1.1 Introduction	2
1.2 Operating Principle	2
1.3 Technical Performance	3
1.4 Product Code (see the Schematic Diagram on the Nameplate)	3
2. Installation	4
2.1. Unboxing/Inspection	4
2.2 Pump Storage	4
2.2.1 Temporary Storage (less than Six Months)	4
2.2.2 Long-Term Storage (for More than Six Months)	4
2.3 Safety Measures	5
2.4 Installation	5
2.5. Leakage Material Collection	6
2.6 Installation	6
2.6.1 NPSH Condition	6
2.6.2 General Pipeline Conditions	7
2.6.3 Suction Pipe	7
2.6.4 Discharge Pipe	7
2.7 Valves	8
2.7.1 Back Pressure Valve	8
2.7.2 Pulsation Damper	8
2.7.3 Safety Valve	8
2.7.4 Non-return Valve	8
2.7.5 Stop Valve	9
2.8 Electrical Wire	9
3. Operation	10
3.1 Initial Startup	10
3.2 Inspection	10
3.3 Start	10
3.3.1 Manual Flow Adjustment	10
3.3.2 Pumping System Filling	10
3.3.3 Flow Calibration	11
4. Maintenance	11
4.1 Preventive Maintenance	11
4.1.1 Drive Part	11
4.1.2 Packing Seal	11
4.1.3 Check Valve	11
4.2 Equipment Repair	12
4.3 Maintenance Procedures	12
4.3.1 Visual Inspection of the Sealing of Mechanical Parts	12
4.3.2 Inspection of the Flow	12
4.4. Spare Parts	12
4.5 Proper Maintenance	15
4.5.1 Preparatory Work	15
4.5.2 Cleaning of the Blocked Check Valve	15
4.5.3 Replacement of Check Valve	15
4.5.4 Replace Packing Seal	15
5. Trouble Shooting	17

Safety Precautions for Metering Pump Operations



warning :

- 1 During the installation or maintenance of the pump, the power supply must be disconnected, and a power off warning sign must be displayed at the switch to prevent accidental operation that could result in personal injury or property damage.
- 2 During the procedure, immediately cease operations upon detection of any warning signals or abnormalities.
3. Using the selected pump within other ranges or operating conditions may result in personal injury or pump damage. Please operate the pump strictly in accordance with its specifications and intended range of use.
- 4 Do not modify the pump or use accessories that have not been tested or approved by the manufacturer; otherwise, users shall bear full responsibility for any resulting personal injury or property damage.
- 5 If the measurement medium is a hazardous or unknown liquid, the operator must wear safety goggles, protective gloves, and protective clothing when operating or maintaining the metering pump.
6. The external power circuit of the pump must be equipped with thermal overload protection compatible with the motor.



pay attention to :

- 7 Ensure that all operators of the equipment are aware of the safety operating procedures or have received relevant training.
- 8 The pump must not operate without lubricating oil; otherwise, the heat generated by friction between its internal components will directly cause pump failure.
- 9 When the pump is not in operation for an extended period, cease its operation and disconnect the power supply. If the medium exhibits physical properties such as high crystallinity, viscosity, or solidification tendency, promptly clean the hydraulic end.
- 10 When Transporting Toxic or Volatile Liquids With Strong Odors, It Is Essential to Ensure Adequate Ventilation at the Handling Point.

I. Introduction

1.1 Introduction

The KJX series pump is a reciprocating plunger metering pump, with a maximum flow rate of 10000L/h per head and a maximum rated pressure of 53 MPa. This series of metering pumps is designed for transporting liquids at temperatures ranging from -10 to 100 °C, free of solid particles, with a kinematic viscosity of 0.5– 800 mm²/s (cst), including dilute slurries as well as general corrosive or toxic chemical media.

Under rated conditions, the pump achieves a steady-state accuracy of ±1% within the 10% to 100% adjustment range.

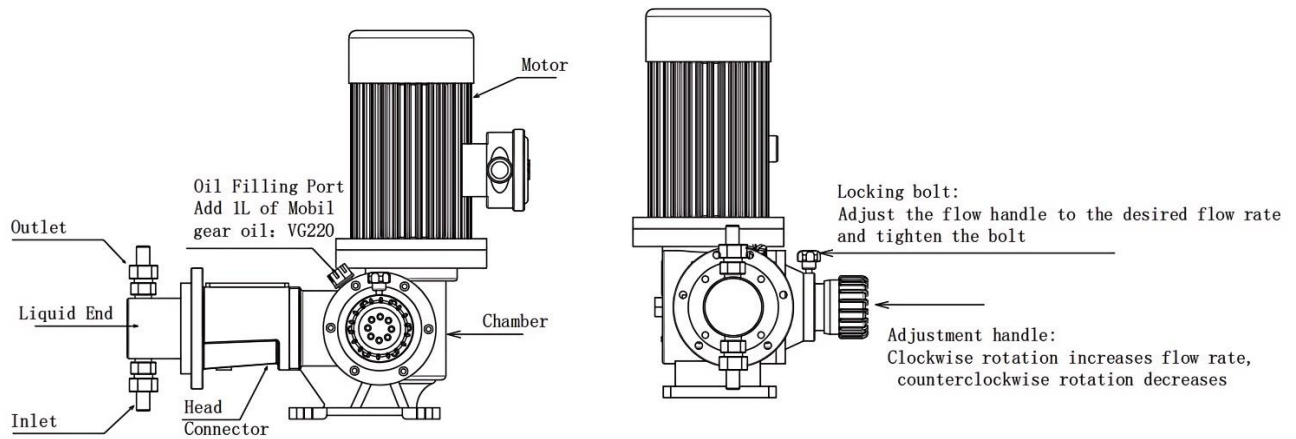

(KJX Series Pump Structure Diagram)

1.2 Operating Principle

The plunger metering pump consists of two main components: the drive section and the liquid end. The pump's output flow rate is a function of the stroke speed of the drive section, the plunger diameter, and the stroke length. A motor rotates the worm gear, which drives a variable eccentric crankshaft. The adjustable crankshaft then converts the rotational force into reciprocating motion of the plunger via connecting rods. The plunger, pump head, inlet/outlet check valves, and sealing materials form a sealed volumetric chamber, known as the hydraulic end.

Inflation stroke: As the plunger moves backward, the pressure within the volume chamber decreases, causing the inlet check valve to open and allowing the fluid in the inlet pipeline to enter the pump head. Upon completion of the inflation stroke, the plunger movement stops instantly, and the pressure inside the pump head balances with that in the inlet pipeline, resulting in the reset of the inlet check valve.

Discharge Stroke: As the plunger moves forward, the pressure within the volume chamber increases, causing the outlet one-way valve to open and forcing the fluid from the pump head into the outlet pipeline. Upon completion of the discharge stroke, the plunger stops instantly, and the pressure inside the pump head balances with that in the outlet pipeline, allowing the outlet one-way valve to return to its original position before initiating the next cycle. The stroke length can be adjusted by modifying the position of the variable eccentric shaft on the connecting rod. During both operation and shutdown of the pump, the stroke length can be altered via the control mechanism.



Note: During the liquid suction stroke, the pressure inside the pump head must be higher than the medium's vaporization pressure. If the liquid pressure is lower than its vaporization pressure, steam erosion will occur, affecting pump performance. In case of concerns about potential steam erosion, please contact the factory.

1.3 Technical Performance

Flow range: 0–10,000 L/h (depending on the pump model)

Maximum export pressure: 53 MPa

Design: Plunger type

Drive: Variable Eccentric Mechanism

Static accuracy: Under rated conditions, the pump achieves an accuracy of $\pm 1\%$ within a regulation range of 10% to 100 %.

Adjustment: A range of 0% to 100 % can be achieved regardless of whether the pump is operating or not.

Lubrication: Oil bath lubrication

Temperature: The maximum temperature of the transported liquid is 100°C, and the minimum temperature is -10°C.

Head: Water suction height is 0.5–5 meters (the higher the flow rate, the greater the suction height).

1.4 Product Code (see the Schematic Diagram on the Nameplate)

Company Name	
Pump Type _____	Model: <u>LJXA0.6/5S4B</u> (See below description)
Max Flow: _____ L/H	Max Pressure: _____ Bar Power: _____ Kw
Serial No. _____	Production Date _____

1. KJ : denotes the plunger metering pump
2. XA denotes the drive mechanism model: XA, XS, and XL represent small mechanisms; ZA and ZL represent medium-sized mechanisms; D represents large mechanisms; T represents extra-large mechanisms; CD represents super-large mechanisms.
3. 0.6 represents the maximum flow rate; the flow rate range is 0–10,000 L/h.
4. The value 5 represents the maximum outlet pressure: The KJXA series plunger metering pump can achieve a maximum outlet pressure of 53 MPa.
- 5.(optional code) S4 Indicates the Material of the wet parts: S4 Stands for SS304, and S6 Stands for SS316.
6. (optional code) B indicates the motor type: B denotes a standard motor; BB denotes a variable-frequency standard motor; and F denotes an explosion-proof motor.FB refers to a variable-frequency explosion-proof motor. W denotes without motor.



Warning: The actual outlet pressure of the pump must not exceed the max operating pressure indicated on the pump nameplate.

2. Installation

2.1. Unboxing/Inspection

Upon receipt of the pump by the carrier, the pump shall be released from the factory and delivered to the user. Any damage incurred during transportation shall be immediately reported to the carrier, and compensation shall be claimed accordingly.

Prior to formal acceptance, conduct a thorough inspection of the transport packaging to confirm that no damage occurred during transit. Open the packaging and verify that all items and accessories are intact, in accurate quantity, and consistent with the packing list. If any discrepancies are identified, promptly contact the manufacturer.

2.2 Pump Storage

2.2.1 Temporary Storage (less than Six Months)

An additional protective layer is added inside the original packaging, thereby isolating it from the external environment. This procedure should be followed under long-term storage conditions in humid climate environments.

2.2.2 Long-Term Storage (for More than Six Months)

The fundamental requirement for equipment preservation is to prevent corrosion of both internal and external components. Such corrosion results from day-night and seasonal variations; it is impractical to prevent the generation of steam and other harmful gases induced by these changes. Therefore, it is essential to protect the surfaces of both internal and external equipment components and minimize the extent of damage caused by corrosion.

The content of this section pertains to equipment storage and measures to prevent direct exposure of equipment to air. The equipment should be positioned at a height of at least 0.3 m above the ground, with its surfaces covered by a plastic film or oilcloth, and adequate ventilation must be ensured to avoid surface moisture accumulation.

2.2.2.1 Pump Drive Section

The pump housing should be filled with an appropriate amount of lubricating oil to prevent rust formation. Fill the housing as completely as possible to minimize conditions conducive to water vapor generation in the air. After the end of the storage period, all oil must be thoroughly drained and replaced with the recommended lubricating oil for equipment debugging.

Remove the hydraulic end and drive motor, apply a uniform layer of multipurpose lubricating oil to all sprayed surfaces, and retain these removed components.

2.2.2.2 Electric Accessory

The motor shall be handled according to the manufacturer's requirements. If no relevant documentation is available, remove the motor and proceed with storage as per Step 3.

Remove all electrical equipment (including motors).

For all electrical equipment, place moisture-proof agents in the packaging and repackage them in sealed plastic bags outside the packaging. Contact the factory to obtain recommended moisture-proof agent materials.

2.3 Safety Measures

Read the instruction manual carefully before installing and operating this product.

This product should be installed in a location with good ventilation and heat dissipation. High temperatures and humidity can easily cause equipment failure.

Before connecting the power supply, ensure that the power specifications are correct.

If this product is connected directly to the pipeline for import or export, ensure that the pipeline is depressurized before installation to avoid hazards.

When operating this product, do not exceed the specified operating pressure and temperature (the maximum allowable temperature for material passage is 100 °C).

This product is not suitable for all fluids; certain solvents, concentrated acids, or highly oxidative fluids may reduce the service life of the contact components.

Chemical safety gloves and protective masks must be worn before handling this product.

Do not modify this product without authorization; no user may alter the design of this product on their own.

Special Note: Failure to install or operate the product in accordance with this manual may result in equipment failure or personal injury.

Before performing any maintenance on the pump, stop the operating equipment. Release the system pressure. Close the inlet and outlet valves connecting the pump to the system. During the maintenance period, prevent any unauthorized actions. Post a notice at the power switch indicating that the equipment is under maintenance. Immediately cut off the power supply if any malfunction is detected during operation (e.g., abnormal temperature or unusual noise).

2.4 Installation

Support the pump with a sturdy and vibration resistant foundation. It is best to have the foundation higher than the ground to prevent it from being washed away by water and to facilitate maintenance. Reserve sufficient space around the pump for maintenance, adjustment, and oil filling or draining. All pumps have installation holes for easy installation of anchor bolts, refer to the installation dimension diagram for installation. The pump installed outdoors should be covered by a rain shelter.

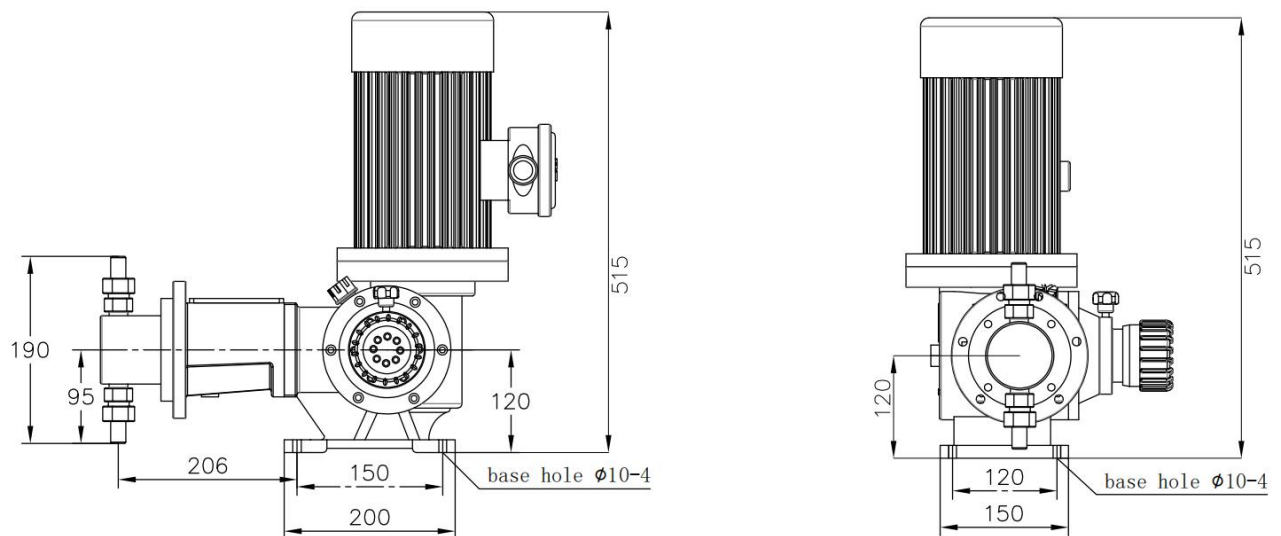

(Installation Drawing for KJXA0.6)

2.5. Leakage Material Collection

A container should be prepared for collecting the leaked fluid or lubricating oil after column packing wear or oil seal rupture. This step is particularly critical when handling hazardous fluids. The container is placed at the base of the connector (see Attachment I) or connected via a flexible hose to the connector, allowing the leaked fluid to be discharged into an appropriate container.

2.6 Installation

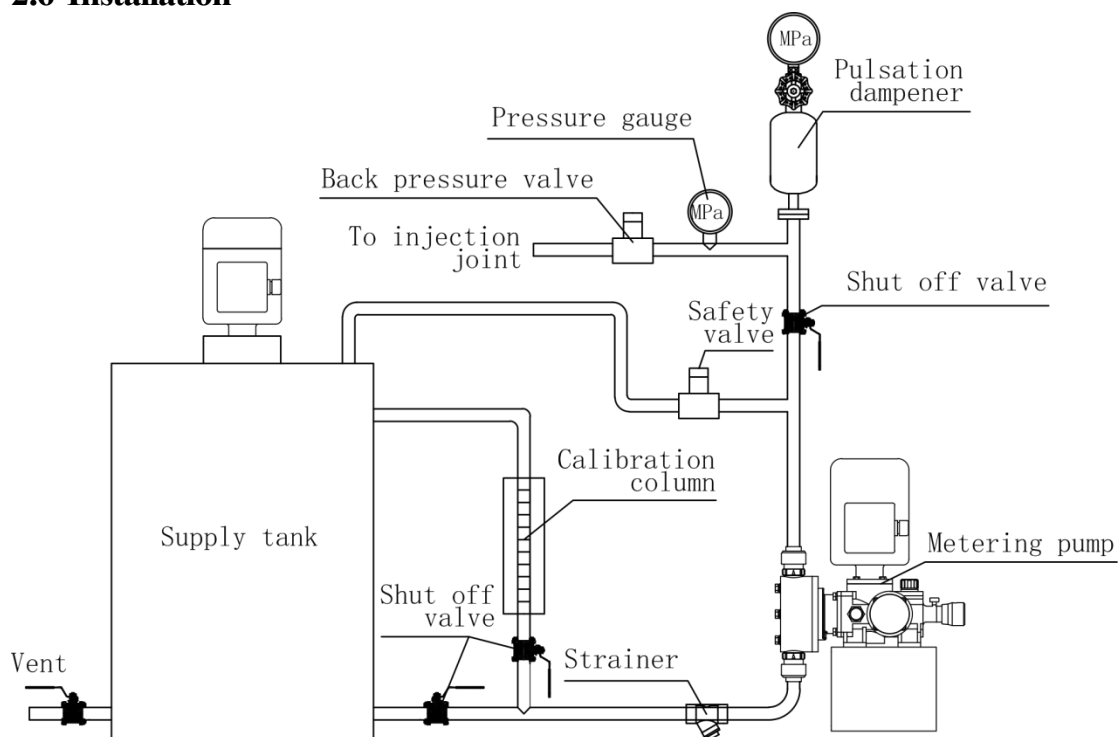

Classic Installation Diagram of Metering Pump

2.6.1 NPSH Condition

The pipeline diameter should be determined based on the instantaneous peak flow rate. Due to the reciprocating motion of the metering pump column plug, the pump's output flow follows an approximate sine curve. The instantaneous peak flow rate is approximately 3.14 times the rated flow rate; therefore, the pipeline must be designed for a capacity of 3.14 times the rated flow rate. For example, a pump with a rated flow rate of 10 L/h requires the pipeline to be designed for a capacity of 31.4 L/h.

When transporting viscous fluids, a suction pipe four times larger than the pump inlet size must be used to minimize flow loss of the viscous fluid. If this cannot be determined, contact the manufacturer to confirm the required pipeline dimensions.

2.6.2 General Pipeline Conditions

Use pipes that can prevent corrosion of solutions. The material shall be carefully selected to avoid electro-chemical corrosion at the junction between the pump head and the external pipe.

Pressure borne by pipes must meet the highest pressure requirement. Remove burrs, sharp edges and debris from the inside of the pipe. All pipes shall be cleaned before final connection.

The pipe shall be slightly inclined to avoid the formation of air section. This is because the air in the pump head will lead to inaccurate the output flow of the pump. For conveying a medium containing suspended solids (like mud), a four-way valve with a pipe plug shall be installed at all 90° elbows so that the pipe can be cleaned without disassembly.

2.6.3 Suction Pipe

It is better to make the pump suction end lower than the minimum level of supply tank so that the solution can be directly injected into the suction end of the pump. In order to reduce the loss of suction pipe of metering pump, the metering pump shall be mounted as close to the supply tank as possible.

Negative pressure liquid suction condition (suction stroke) shall be avoided for it will affect the measurement accuracy. The suction stroke of the 2.5m water column is the maximum allowable suction height. (There are slight differences among different models)

The pump shall operate under the condition that the inlet pressure is equal to or slightly higher than the atmospheric pressure. Although the pump can operate when the inlet pressure is lower than the atmospheric pressure, under the negative pressure condition, it is important that all joints are absolutely leak-free and vacuum tight. At the same time, a foot valve shall be installed at the bottom of the suction pipe.

When conveying liquid close to the boiling point, sufficient suction pressure shall be provided to avoid vaporization of the liquid as it enters the pump head during suction stroke.

If possible, a metal suction pipe shall be used as far as possible. This is because such a pipe has a smooth inner wall and uses a large turning radius to reduce the resistance loss of pipe.

The suction pipe shall be installed with a Y-type filter with more than 60 meshes to prevent external particles from entering into the pump head. Avoid maintenance due to the blockage of the check valve by residue. It is necessary to inspect the filter regularly to prevent blockage. The suction pipe shall be as short and straight as possible.

The diameter of the suction pipe shall be larger than the size of the pump head inlet to avoid lack of liquid.

When a long-distance suction pipe must be used, a vertical pipe riser shall be installed in the suction pipe near the pump.

The suction pipe must be absolutely airtight to ensure accurate flow. After the pipe is installed, test the suction pipe for leakage with air and soap.

2.6.4 Discharge Pipe

Install a large enough pipe to avoid excessive pressure loss during pump discharge stroke. The maximum pressure of the outlet pipe must be maintained at or below the maximum allowable working pressure indicated on the pump nameplate.

If the pressure difference between the inlet and outlet of the metering pump is small, to ensure the metering accuracy, you can establish the outlet pressure manually by installing the back pressure valve. When transferring water treatment chemicals directly to the boiler, use a separate metering pump for each boiler. The discharge to the branch will reduce the measuring accuracy; even if the pressure difference at each dosing point is slight, the flow at lowest pressure dosing point is greater than that of other dosing points.

2.7 Valves

2.7.1 Back Pressure Valve

When all metering pumps work under low system pressure, there will be excessive transmission. To prevent similar problems, it is necessary to maintain a certain back pressure at the outlet of the metering pump. The purpose can be achieved by installing back pressure valve in the outlet pipe of metering pump. Generally, the back pressure valve shall be installed close to the pump outlet. However, for large flow pump and long and thin outlet pipe, the back pressure valve shall be installed close to the outlet to reduce the siphon trend.

2.7.2 Pulsation Damper

The pulsation damper is used together with the back pressure valve in the outlet pipe to absorb the peak flow between the pump and the back pressure valve. Without pulsation damper, the back pressure valve will open and close rapidly with each pump stroke. When there is a pulsation damper, the back pressure valve will oscillate in the half open and half closed positions, thus reducing the wear rate of the back pressure valve. The greater advantage of the pulsation damper of the outlet pipe is to limit the flow and pressure variation characteristics of the metering pump. Installing a pulsation damper of appropriate volume will improve the pump's working performance, a small-diameter pipe can be used, which greatly reduces the cost of the system.

2.7.3 Safety Valve

A motor-driven metering pump may have a large discharge pressure before the thermal protection element cuts off the electrical control circuit of the motor. To avoid damage to the pump, pipe or equipment due to the blocked outlet pipe, a safety valve shall be installed on the outlet pipe of the pump. The safety valve can safely and effectively control the flow and pressure of the system, and the material of the safety valve shall be resistant to the corrosion by liquid. Installing a safety valve on the outlet pipe between the pump and the nearest stop valve can avoid pump damage due to accidental closing of the valve. Liquid from the safety valve outlet pipe returns to the supply tank or is drained. However, in any case, the end part of the pipe shall be visible so that the leakage from the safety valve can be easily detected. The safety valve must be installed at the top of the supply tank to ensure normal operation.

2.7.4 Non-return Valve

A check valve shall be installed before the outlet pipe reaches the boiler or other high pressure vessel, which can avoid back flow of the outlet pipe and isolate the pump discharge end from system pressure (for the sake of safety).

2.7.5 Stop Valve

Stop valves shall be installed at both ends of the suction pipe and the outlet pipe of the pump. The stop valve of the outlet pipe shall be located downstream of the safety valve inlet connection pipe.

2.8 Electrical Wire



Warning: reverse running of the motor will damage the pump and motor and is not covered by the warranty. Don't forget to ground the pump and equipment. Ensure that the power supply parameters are consistent with the parameters specified on the pump motor nameplate. Conduct wiring according to the motor wiring diagram (possibly in the junction box) and user manual.



Attention: before running the pump, check the rotation direction of the motor and ensure that it is consistent with the arrow on the motor mounting flange (clockwise when viewed downwards from the fan blade side of the motor). The electrical protection of the motor (fuse or thermal protection) shall correspond to the rated current of the motor.

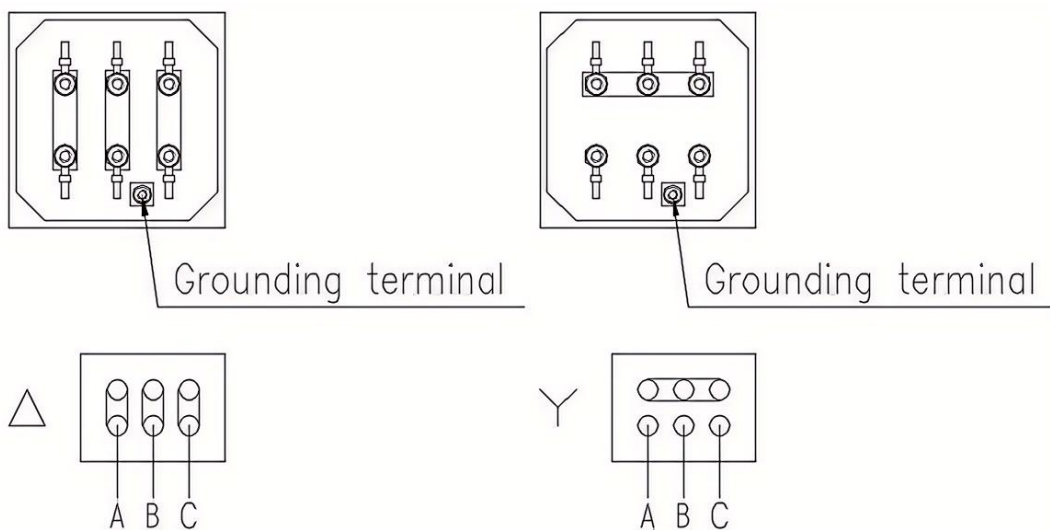

200V Triangle
Wiring Method

380V Start-shaped
Wiring Method

Schematic Diagram of the Motor Junction Box and Wiring Method



Attention: the motors of different manufacturers are wired differently. Please refer to the specific instructions of the motor junction box. Do not forget to ground the pump!

3. Operation

3.1 Initial Startup

Check whether all assembly bolts are securely fastened, whether the piping is correctly installed, and whether the discharge piping is open. Inspect whether the gear oil drain plug is tightened, remove the gear oil filling cap, and add an appropriate amount of gear oil to the pump body (the required quantity is specified in Appendix 1).



Attention: the gear oil had been discharged thoroughly before delivery and the pump must be filled with gear oil before start, or worm gear and worm will be damaged.

Gear oil grades are listed as follows.

	Ambient temperature >-5°C	Ambient temperature -10°C~5°C
Gear oil grade	MOBILGEAR 600 XP 220	MOBILGEAR 600 XP 68



Cautions: The pump is strongly proposed to stop running below -10°C. Before the pump is powered on, adjust the flow adjusting cylinder to zero. Before the flow adjusting cylinder is adjusted increasingly from zero, inspect the suction and discharge pipes to ensure all the globe valves are open.

3.2 Inspection

Start the metering pump and check the rotation direction of the motor. The rotation direction must be consistent with the arrow on the fan cover of the motor (clockwise when viewed downwards from the fan blade side of the motor). If the rotation direction is not correct, refer to the motor nameplate or "Electrical Wiring" and change the wiring.

3.3 Start

3.3.1 Manual Flow Adjustment

Loosen the adjustment screw located on the side of the pump housing to regulate the pump flow rate. Rotating the adjustment sleeve changes the flow rate: rotating clockwise reduces the flow rate, while rotating counterclockwise increases it. The entire stroke adjustment range is indicated in percentages; the minimum adjustment increment on the handle is 0.5%. After setting the desired flow rate using the adjustment handle, tighten the locking screw manually to maintain the specified flow rate.

3.3.2 Pumping System Filling

Exhaust from the pump suction pipe and outlet pipe is a very important step. Thus before pressure test, run the pump under the condition of no discharge of pressure to fill the delivery system with liquid. A simple way to ensure filling is to install a three-way valve and stop valve at the outlet end of the pump.

If the pump is kept used for a long time, the liquid temperature change can generate gas in the system. To discharge the air, one valve can be mounted on the outlet pipe to discharge the air through the process material at the start of the pump.

3.3.3 Flow Calibration

After the initial 12 hours of pump operation, a flow calibration test should be performed to determine the precise flow rate under specific operating conditions. Typically, setting the pump's flow rate at 100%, 50%, and 30% of its rated capacity is sufficient to characterize the pump's performance across the entire control range. By measuring the change in liquid level within a calibration vessel, the pump's flow rate can be calculated. This method is recommended for calibrating hazardous liquids. The calibration column can be used to calibrate any type of pump. Collecting and measuring the discharged liquid at the pump outlet also allows for flow rate calibration; however, it is essential to establish the discharge pressure at the outlet point to ensure accurate pump operation.



Warning: it is suggested not to adopt the later method to calibrate the flow because the operator will face the dangerous liquid directly, which may result in accidents. Besides, when the flow is measured by this method, it is likely that the pump is in a self-flowing state, and the measured data will not be accurate.

4. Maintenance

4.1 Preventive Maintenance

4.1.1 Drive Part

After the first 1,000 hours of operation, the gear oil for metering pump drive part shall be replaced. After that, replace the gear oil every 5,000 hours or half a year later. Refer to "3.1 Initial Start" for gear oil grade

4.1.2 Packing Seal

The packing seal of KJ series plunger pumps should be checked and replaced every 4000 hours of operation to avoid malfunctions. The replacement of worn packing seal should refer to "4.5 Correct Maintenance".

The leakage rate at the plunger packing seal should refer to the GB/T 7 8 2-2020 standard (see table below for details). If the leakage rate exceeds the standard, the packing locking ring should be tightened appropriately after stopping the pump, but not too tightly, otherwise it will cause the temperature of the packing seal to rise, resulting in shaft holding or burning of the sealing packing of the plunger.

Rated pump flow Qr(L/h)	Leakage≤
≤1	0.1%Qr
>1~10	0.05%Qr
>10	0.01%Qr

4.1.3 Check Valve

It is recommended to replace the ball, seat and O-ring of the check valve every 5000 hours or every year. If the pump delivers highly corrosive materials (such as

acid, sizing agent, etc.), it is necessary to check and replace the spare parts frequently. To replace the worn check valve, refer to "4.5 Proper Maintenance".

4.2 Equipment Repair

If the "repair authorization" is not obtained from the factory, the factory cannot accept the repair of the pump. The pump to be repaired shall be clearly marked with the material delivered, and the pump head shall be flushed and the gear oil in the casing shall be drained before the pump is delivered.



Attention: a complete material safety data sheet shall be provided in the packaging box for the equipment to be repaired. These safety measures are helpful for fault inquiry and repair and can also avoid injury of maintenance personnel due to residual materials in the pump head.

4.3 Maintenance Procedures

With careful design, manufacturing, assembly and quality testing, the KJ series metering pump can realize reliable performance and less maintenance. However, it is still recommended to conduct maintenance inspection every week to ensure normal operation.

4.3.1 Visual Inspection of the Sealing of Mechanical Parts

Check the following parts for leakage.

1. Flow adjusting cylinder: in case of any leakage, replace the seal ring of stroke adjusting rod.
2. Connector bottom hole: in case of any leakage of gear oil, replace the framework oil seal; in case of any leakage of material delivered, pre-tighten the locking ring again or replace the plunger packing seal.

4.3.2 Inspection of the Flow

Confirm that the metering pump flow has been calibrated according to the content of "3.3.3 Flow calibration". Close the valve connecting the supply tank to open the globe valve of calibration column. Measure the flow delivered by the metering pump under different flow settings. If there is no calibration column in the suction pipe, a calibration container (with scale) shall be connected to the outlet pipe. Measure the flow delivered by the metering pump under different flow settings.

4.4. Spare Parts

Liquid end of the KJ series plunger pump, see Appendix 4 (KJ series plunger metering pump check valve assembly)

Drawing	Spare part name	Quantity	Drawing	Spare part name	Quantity
See Appendix 4	Valve ball	See Appendix 4	See Appendix 4	Seal 1	See Appendix 4
	Valve seat			Packing seal 2	
	Valve Cover			Check valve gasket	

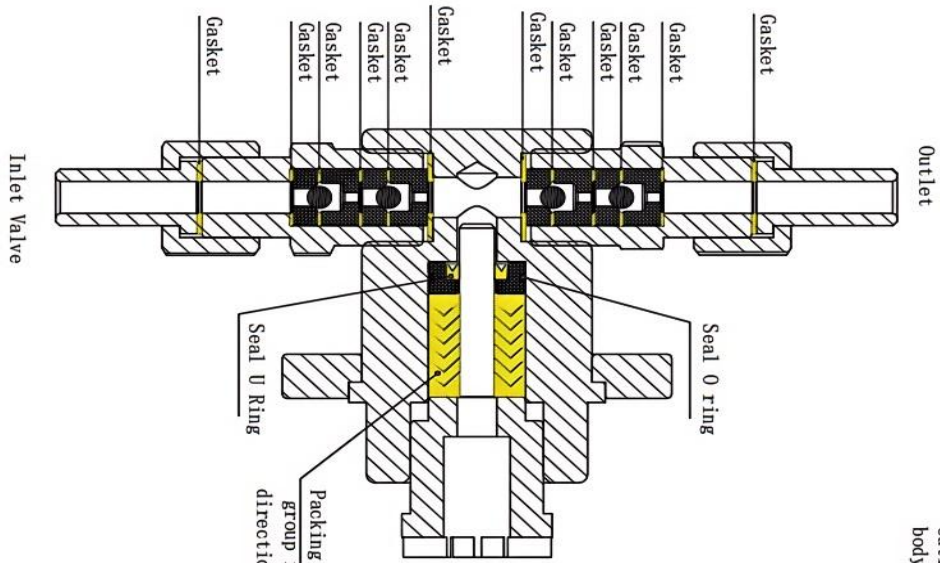

Outlet check valve: To prevent the parts inside the valve body from falling out during the installation of the outlet check valve, first loosen the pump head pressure plate to turn the outlet downwards, then screw on the valve body, and then turn the pump head outlet upwards. Note that the valve body must be facing vertically upwards

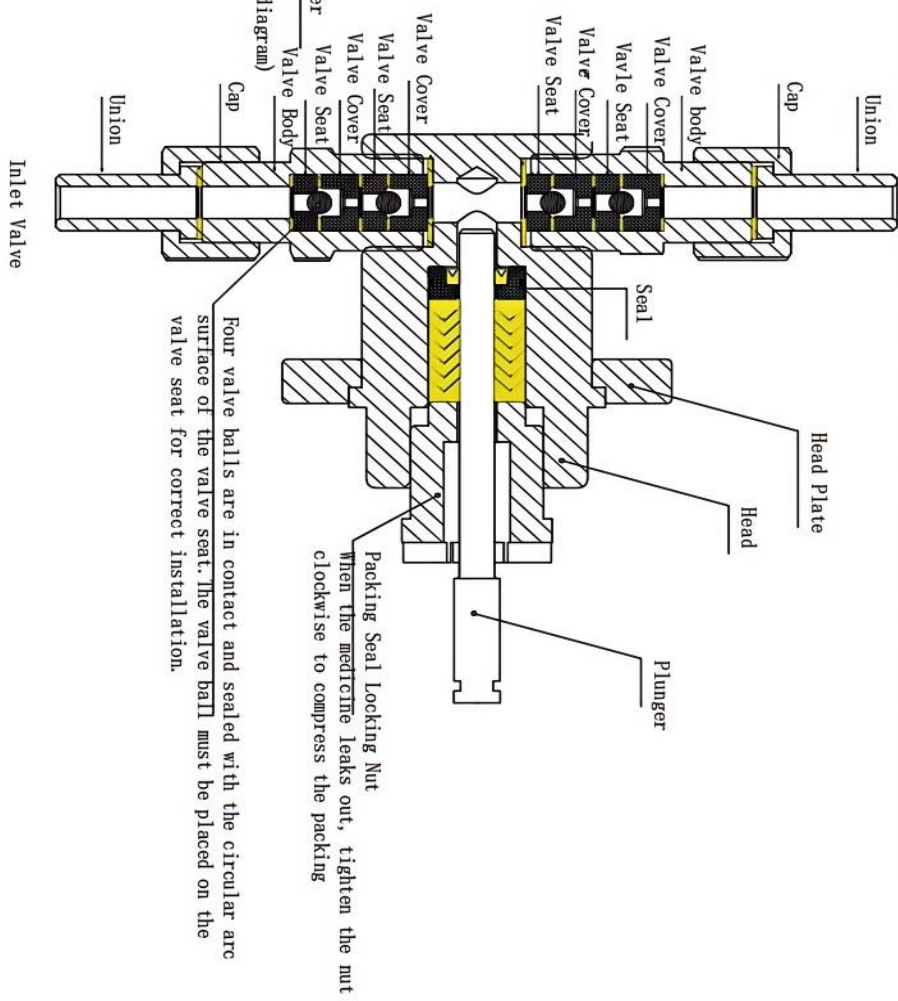

Appendix 4 (Liquid end of the KJ series plunger pump)

The driving parts of the KJ series plunger pump are shown in Appendix 5(Cross-sectional diagram of the KJ series plunger metering pump).

Drawing	Spare part name	Quantity
See Appendix 5	Worm gear	See Appendix 5
	Worm	
	Worm bearing	
	Sliding rod oil seal	

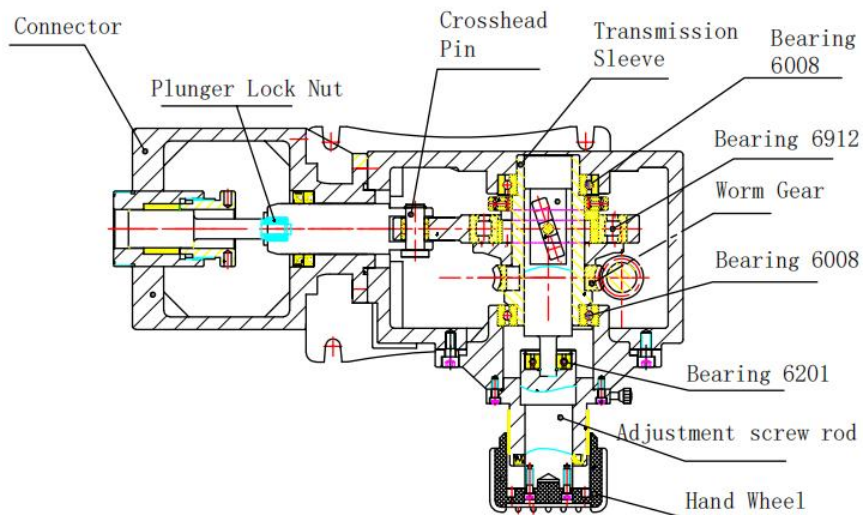
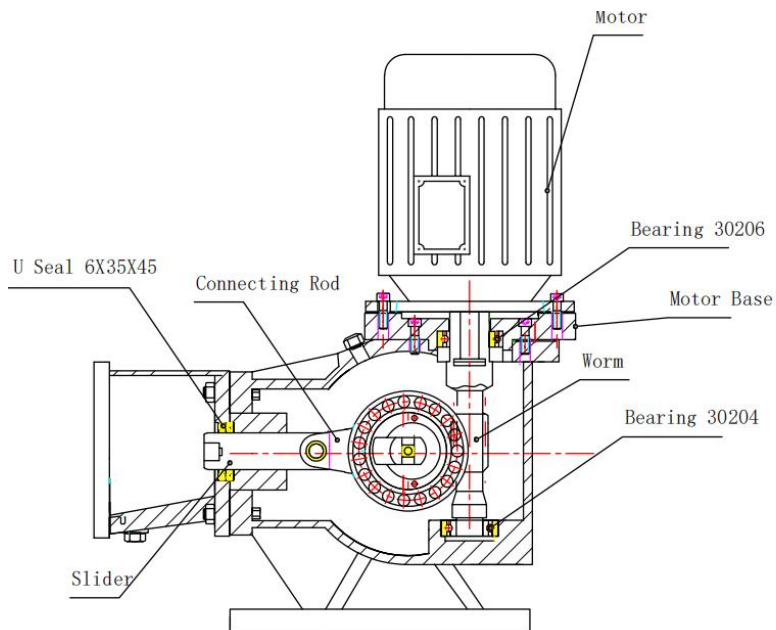

Appendix 5(Drive end of the KJ series plunger pump)

The procurement of spare parts must include the following:

1. Quantity required
2. Spare Parts Name
3. Pump Serial Number (indicated on pump nameplate)
4. Pump model (indicated on pump nameplate)

Note: Product code and serial number should be in compliant with the equipment.

4.5 Proper Maintenance



Warning: before any maintenance of the metering pump and pipes, the power supply shall be cut off and necessary measures shall be taken to prevent harmful materials from contacting with operators. Proper protective equipment must be provided to ensure that there is no pressure in the pump or system.

4.5.1 Preparatory Work

1. Adjust the scale of the flow adjusting cylinder to 0%. If the stroke set screw is locked, loosen the set screw.
2. Cut off the power supply to ensure that the equipment will not be accidentally started up. Hang a notice at the power switch to inform that "The equipment is in maintenance".
3. Cut off the connection between the inlet and outlet check valves of metering pump and the system.

4.5.2 Cleaning of the Blocked Check Valve

The check valve is designed as self-cleaning mode, rarely requiring maintenance. Blocked check valve usually can be cleaned with dilute neutral detergent and warm water (if compatible with the conveyed material) pumped for 15min, and then rinsed with water.

4.5.3 Replacement of Check Valve

Before handling the check valve, it should be confirmed that the shut-off valve has been closed and the system pressure has been released. When replacing the check valve, the PTFE gasket must also be replaced. Refer to KJ sectional view, pay attention to the correct assembly sequence of the check valve.

4.5.4 Replace Packing Seal

Packing seal 1:

1. Remove the pump head and take out the packing 1 in the pump head;
2. Dress the new packing O-ring on the pump head, press the PTFE ring into the reniform shape shown in Fig. A without sharp corner, make the gap face the pump head, install it into the O-ring, and then rotate the calibration spindle for recovery.

Packing seal 2:

1. Remove the pump head, take out the packing box, and take out a group of six pcs. of packing seal 2;
2. Install the new packing as shown in "Fig. 6b": install a piece of metal packing (convex V-side facing outward) into the packing box, and then install a piece of graphite fiber packing (concave V-side facing inward) into the packing box in

"Direction A" as shown in the Figure; after that, install the four pieces according to the sequence and direction, install the metal packing and graphite packing at intervals, and properly tighten the locking ring.



Attention: the packing is a vulnerable part, and the locking ring shall be adjusted periodically.

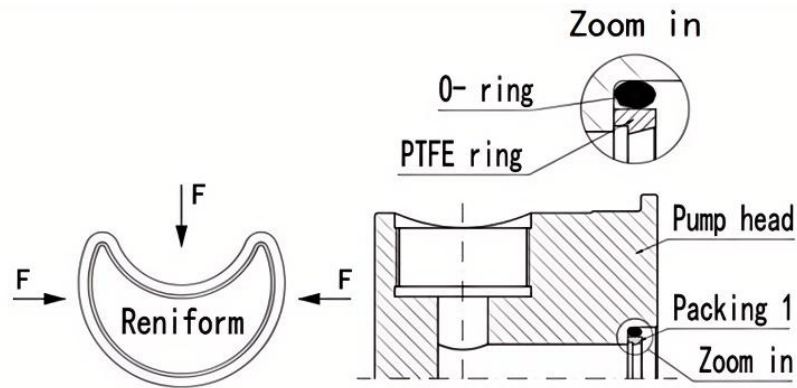

Packing 1 Installation Diagram (Fig. A)

Packing Seal 1 Installation Diagram (Fig. A)

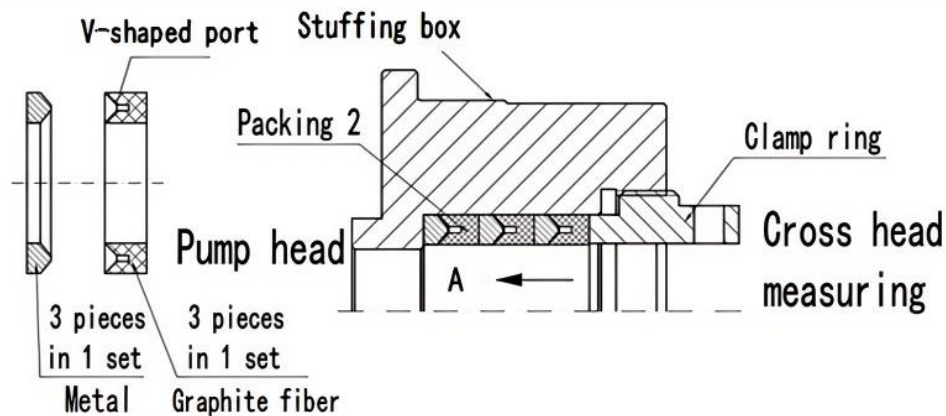

Packing Seal 2 Installation Diagram (Fig. B)



Warnings: the assembly position and sequence of inlet and outlet check valves are different, and please follow the instructions carefully and refer to the correct legend during disassembly and assembly of check valves. If the check valve is not installed properly, the following phenomena will occur:

(A) The mechanical structure of metering pump may be badly damaged immediately.

(B) No liquid is output.

(C) The liquid is conveyed in a reverse direction (from the outlet pipe to the inlet pipe).



Attentions:

1. To ensure sealing without leakage, a new O-ring shall be used every time the check valve is disassembled.
2. PTFE tape shall not be used on the expansion joint thread, so as to prevent the O-ring from being pressed tightly and causing leakage.

5. Trouble Shooting

Trouble	Fault Reason	Troubleshooting Method
Operation failure of pump	The liquid level is low(adopt low level to disconnect the device)	Add solution to the storage tank.
	Check valve is blocked or damaged.	Clean or replace the check valve.
	The outlet pipe is blocked.	Clean and unblock the pipe.
	Liquid is frozen.	Melt frozen liquid in the entire dosing system.
	The fuse is blown.	Replace the fuse.
	The thermal overload device in the motor starter trips.	Reset the thermal overload device.
	The cable is disconnected.	Find out its location and repair it.
	The voltage is excessively low.	Test and correct it(the cable may be too thin).
	The pump is not filled with liquid	Before conveying the liquid to the pressure pipe,the suction pipe and the pump head shall be filled with liquid Please refer to "3.3.2 Pumping system filling".
Stroke is set to zero.	Readjust stroke setting	
insufficient quantity of liquid pumped out	Stroke setting is improper.	Readjust stroke setting
	Pump operating speed is improper	Make the supply voltage and frequency match the data on the pump motor nameplate.
	Insufficient suction	To increase suction tube aperture or suction pressure.
	The suction pipe leaks.	The valve is blocked or valve seat is worn out.
	Suction lift is excessively high.	Rearrange the equipment to reduce the suction lift.
	Liquid is too close to boiling point	Reduce temperature or increase suction pressure.
	Safety valve in the outlet pipe leaks.	Repair or replace the safety valve.
	Liquid viscosity is too high	Reduce the viscosity by heating or other means,or increase the suction diameter,or increase the suction pressure.
	Check valve seat is worn or contaminated.	Clean or replace it.
	There is air in the pipeline system	To empty air in the system.
Suction tube is leaking.	The suction pipe leaks.	The valve is blocked or valve seat is worn out.
	The check valve is blocked or valve seat is worn out.	Clean or replace the check valve assembly.
	Suction pressure is insufficient.	Raise the liquid level of storage tank or boost the storage tank.
	Liquid is too close to boiling point	Reduce temperature or increase suction pressure.
	The pipe filter is blocked or polluted.	To wash the filter.
	Safety valve in the outlet pipe leaks.	Repair or replace the safety valve.

Overheating of the motor and pump body	Operating temperature of motor and pump body is too hot frequently via touch	Normal temperature shall not exceed 93°C.
	The power supply is inconsistent with the motor's electrical specification.	To confirm that the power supply matches with the motor correctly.
	Pump operates under the condition of exceeding the rated performance.	To reduce the pressure or stroke speed. If this doesn't work, please contact the factory.
	The lubricant is incorrectly filled into the pump.	Drain the oil and refill the proper amount of recommended lubricating oil.
Liquid continuously conveyed by the pump with zero stroke	Flow calibration is improper.	Re-calibrate it.
	Adjust the adjusting cylinder improperly.	Readjust stroke setting
	Insufficient difference of outflow	Change the operation conditions (add a back pressure valve, for example).
Gear noise is too loud.	The bearing is worn	Please contact the factory.
	Lubricant grade is wrong or filling amount is insufficient.	To replace or add the lubricant
Loud impact during every stroke	The gear component has excessive lose.	Please contact the factory.
	The bearing is worn	Please contact the factory.
Noise at hydraulic end in operation	Noise in the check valve	The valve ball moves up and down under a certain external force, and a kind of special "click" noise is normal, especially in the metal pipeline system.
There is material leaking from the detection hole.	Plunger packing is worn	It is necessary to pre-tighten the locking ring again or replace the plunger packing.
There is material leaking from the lubricating oil.	The framework oil seal is ruptured.	It's necessary to replace the framework oil seal.